

YAMAHA MARINE

# HOT SHEET



EFFECTIVE NOVEMBER 1, 2009

## F6 / F4 Portables *fourstroke*

**You want power. You want performance. You want portability. You want Yamaha.**

***Introducing the all-new Yamaha F6 / F4 portable outboards.***

Weighing in as light as 60 pounds, these new Yamaha portables mean you can have all the benefits you want and need in a portable outboard. Truly compact, light weight, and easy-to-handle, these pint-sized protégés of our larger outboards are feature-packed and offer the outstanding reliability you've come to demand from Yamaha.

Available in both 15" and 20" models, they're among the most fuel-efficient in their class, and all models proudly feature a CARB 3-star rating for ultra-low emissions.

***The new Yamaha F6 and F4 portables. Proof positive that a little goes a long way.***



- **Powerful Performance** – OHV design with an advanced ignition system.
- **True Portability** – light weight with built in carrying handles.
- **Fuel Efficiency** – carbureted single-cylinder, with a standard built-in fuel tank and optional external fuel tank compatibility for extended range.
- **Ultra-low Emissions** – featuring a CARB 3-star rating.
- **Operator Convenience** – advanced tiller handle features, Shallow Water Drive, and aluminum propeller; standard.
- **Smooth and Quiet** – optimally-balanced Yamaha four stroke design.
- **Easy Maintenance and Storage** – featuring Yamaha's new Easy Storage Oil Retention System.
- **Lasting Value** – Yamaha reliability with advanced features help protect your investment for years of trouble-free enjoyment.
- **Peace of Mind** – three-year pleasure or government limited warranty.

AVAILABLE MODELS: F6SMHA • F6LMHA • F4SMHA • F4LMHA



# F6 / F4 Portables Four Stroke

## FEATURES



### Power/Performance

- 1.1L Built-In See-Through Fuel Tank
- Built-In Auxiliary Priming Pump
- Fuel Tank Switching Valve
- Water Resistant Fuel Tank Cap
- Built-in Fuel Filter
- External Fuel Tank Connector Cover
- Tilted Fuel Filler

- Tiller Handle Damper with Dynamic Balancer
- Easy Grip Starter Knob
- Ergonomically-Designed Throttle Grip
- Built-In Rear Carrying Handle
- Ergonomically Designed Front Handle
- Large Shift Lever
- Large Toggle Clamp



### Reliability/Durability

- CDI Ignition with Built-In Coil
- 12V-6Amp Alternator with Rectifier (Optional)

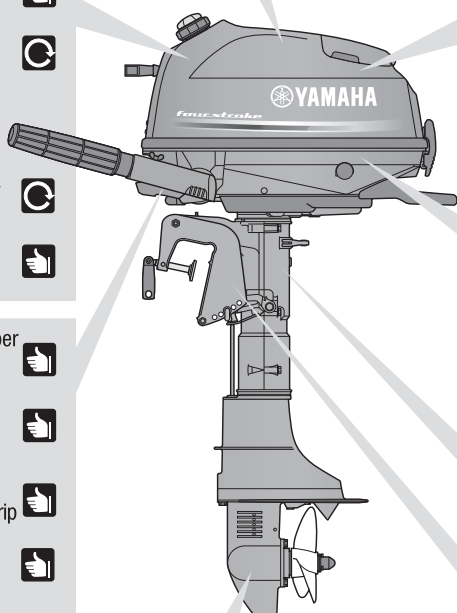

- Splined Prop and Prop Shaft
- New Propeller Sizes (Optional)



### Convenience/Control

- Optimally Balanced Crankshaft
- Bottom Cowling Damper
- Easy Start Decompression Device
- Blow-By Gas Reburning System
- Precise Carburetor Setting

- Pressurized Oil System
- Lubrication Check Window
- Easy Storage Oil Retention System

- Labyrinth Exhaust

- 90° Each Direction Steering
- 3-Step Shallow Water Drive
- Long-Span Mounting System
- 5 Step Trim Adjustment

### Warning & Protection System

- Over-Rev Limiter

### Ultimate Corrosion Protection System

- Special Aluminum Alloy: YDC30
- Self-Sacrificing Anodes
- Start-In-Gear Protection

## MODEL CODE CHART (EXAMPLE)

F	6	S	M	H	A
Fuel Induction	Horsepower	Shaft Length	Starting Method PTT	Control Method	Generation
F = Four Stroke		<b>S = 15"</b> L = 20" X = 25" U = 30" J = Jet	Blank = PTT & E start P = PT & E start E = Electric Start <b>M = Manual Start</b>	Blank = Remote Control <b>H = Tiller Handle</b> C = Command Link Control	<b>A = 1st change on motor</b> B = 2nd change on motor C = 3rd change on motor Etc.

# F6 / F4 Portables Four Stroke

## PERFORMANCE, RELIABILITY, CONVENIENCE

### LIGHTWEIGHT, PORTABLE POWER

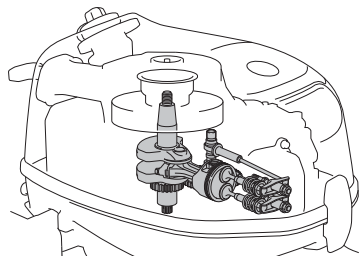

Weighing in as light as 60 pounds, these 139cc OHV single cylinder four stroke powerhouses offer a CDI ignition system, optimally-balanced crankshaft, long span mounting system, labyrinth exhaust and a host of other features for smooth, quiet power. They even have built-in carrying handles for true portability and convenience.

### RELIABLE LUBRICATION AND STORAGE

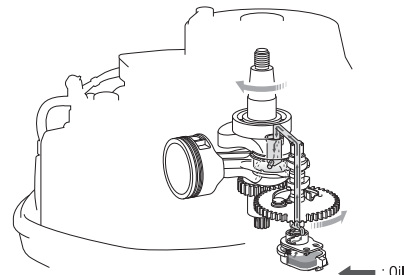

Yamaha's new F4 and F6 both feature a pressurized oiling system. They can be stored on either side or on the front grip without fear of oil leakage, due to Yamaha's exclusive Easy Storage Oil Retention System.

### MAXIMUM EFFICIENCY

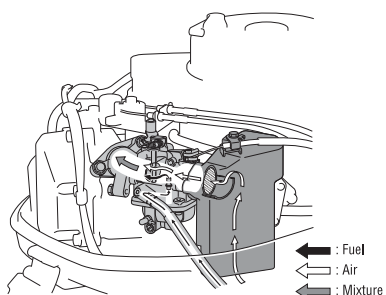

The carburetor and its setting is factory-selected for maximum fuel efficiency, helping these outboards achieve a 3-star C.A.R.B. emissions rating. Additionally, automatic decompression, built-in auxiliary priming, and start-in-gear prevention help make for easy, safer starts.

### COMFORTABLE, CONVENIENT CONTROL

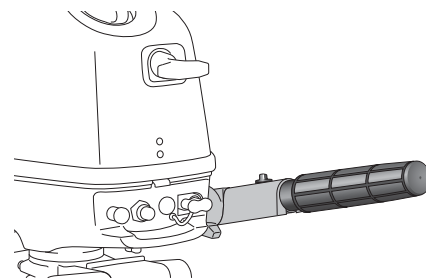

With a dynamically-balanced and dampened large twist-grip throttle, 180-degree steering, and large F-N-R shift handle; comfortable, convenient control is key.

### EASY OPERATION

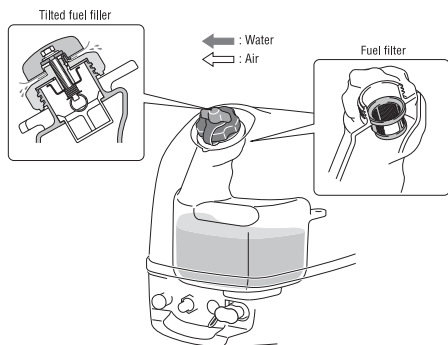

A 1.1L see-through fuel tank is built in, with switchable access to an optional external tank for extended range. A tilted, water-resistant fuel filler cap and built-in fuel strainer add to both the convenient operation and reliability of these outboards.

### VERSATILE PERFORMANCE

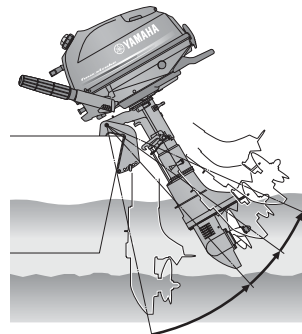

A 5-step trim adjustment couples with a 3-step Shallow Water Drive System to help make these outboards perform in various conditions. A splined propeller shaft and an expanded selection of available propeller sizes give you performance that's versatile and easy to handle and operate.

# F6 / F4 Portables Four Stroke

## SPECIFICATIONS

### ENGINE

Type	One-Cylinder
Displacement	139cc (8.5 ci)
Bore x Stroke	62 x 46mm (2.44 x 1.81 in)
Full Throttle RPM Range	4000 ~ 5000 (F4) 4500 ~ 5500 (F6)
Horsepower Rating at Propshaft	4hp at 4500 rpm (F4) 6hp at 5000 rpm (F6)
Compression Ratio	8.9:1
Fuel Induction/Scavenging	OHV
Alternator Output	6 Amp (Optional: Requires Charging Kit)
Starting Method See Model Code	M = Manual
Ignition	CDI
Lubrication	Wet Sump
Degree of Trim	5 positions
Degree of Tilt	69°
Exhaust	Above Propeller
Cooling	Water/Thermostatic Control

### DRIVE

Gear Shift	Forward, Neutral, Reverse
Gear Ratio	13:27 (2.08)

### SHAFT LENGTH

See Model Code	S = 15" L = 20"
----------------	-----------------

### FUEL AND LUBRICATION

Recommended Fuel	Regular Unleaded (Minimum Pump Octane 87)
Fuel Tank Capacity (Integral)	1.1L (.29 gal)
Ethanol Blend Limit	10% Maximum
Recommended Oil	Yamalube® 4M (See owner's manual)
Engine Oil Capacity	.6L (.63 qt)

### WEIGHT

F6SMHA	27kg (60 lbs)
F6LMHA	28kg (62 lbs)
F4SMHA	27kg (60 lbs)
F4LMHA	28kg (62 lbs)

### LIMITED WARRANTY

Pleasure	Three Years
Government	Three Years
Commercial	One Year

## FEATURES

### POWER/PERFORMANCE

- Four Stroke Engine Design
- OHV
- 2-valves Per Cylinder
- Precise Carburetor Setting
- Built-in Auxiliary Priming Pump
- Streamlined Intake Manifold
- Long Span Mount System
- Oil Separator
- Streamlined Gearcase
- Dynamically Balanced Crankshaft
- Labyrinth Exhaust
- California C.A.R.B. Ultra Low Emissions 3 Star Rating
- Meets all current Federal EPA Emission Standards

### RELIABILITY/DURABILITY

- CDI Ignition System
- Pressurized Lubrication
- Thermostatic Temperature Control
- Sacrificial Anodes
- ACP 221 Paint Process
- SST Drive, Prop, Shift Shafts
- Splined Propeller/Shaft
- Built-in Fuel Filter

### CONVENIENCE/CONTROL

- 180-Degree Steering w/F-N-R Shifting
- Shallow Water Drive
- Easy Storage Oil Retention System
- Standard Tiller Handle
- Easy Start Decompression Device
- Lubrication Check Window
- Multiple Gripping Points
- Dual Transom Clamps
- Dynamically Balanced Tiller Handle
- Lower Cowling Damper
- Built-In See-Through Fuel Tank
- Tilted Fuel Filler Opening
- Selectable External Fuel Tank (Optional)
- Forward/Neutral/Reverse Shifting

Primary ID Prefix: (F6) 6BX (F4) 6BV

This document contains many of Yamaha's valuable trademarks. It may also contain trademarks belonging to other companies. Any references to other companies or their products are for identification purposes only, and are not intended to be an endorsement.

Due to Yamaha's ongoing commitment to product improvement, we reserve the right to change without notice, equipment, materials, or specifications.

▲ Consult appropriate Yamaha rigging information and Yamaha Rigging Sheet (YMBS) for complete rigging compatibility and requirements information for particular configurations. All rigging items sold separately.

© 2010 Yamaha Motor Corporation, U.S.A. All rights reserved.

