

Yamaha V-6 Offshore Four Stroke Outboards

SPECIFICATIONS

ENGINE

Type	60° V6
Displacement	4.2 Liter
Bore x Stroke	96 x 96mm (3.78 x 3.78 in)
Full Throttle RPM Range	5000 ~ 6000
Horsepower Rating at Propshaft	300hp at 5500 rpm (F/LF300) 250hp at 5500 rpm (F/LF250) 225hp at 5500 rpm (F/LF225)
Compression Ratio	10.3:1
Fuel Induction/Scavenging	EFI/VCT/DOHC
Alternator Output	70 Amp
Starting Method	Electric w/ PTT
See Model Code	
Ignition	TCI Microcomputer
Lubrication	Wet Sump
Degree of Trim	-3° through +16°
Degree of Tilt	67°
Exhaust	Through Propeller
Cooling	Thermostatic Control

DRIVE

Gear Shift	Forward, Neutral, Reverse
Gear Ratio	12:21 (1.75)

SHAFT LENGTH

See Model Code	X = 25" U = 30"
----------------	-----------------

FUEL AND LUBRICATION

Recommended Fuel (for best performance)	F/LF300 (Min. PON 89) F/LF250 (Min. PON 87) F/LF225 (Min. PON 87)
Recommended Fuel Filtration	Yamaha 10-Micron Fuel/Water Separating Filter (external)
Ethanol Blend Limit	10% Maximum
Recommended Oil	Yamalube® 4M (See owner's manual)
Engine Oil Capacity	6.5L (6.9 qt) with filter

WEIGHT

F/LF300XCA	255kg (562 lbs)
F/LF250XCA	255kg (562 lbs)
F/LF225XCA	255kg (562 lbs)
F/LF300UCA	263kg (580 lbs)
F/LF250UCA	263kg (580 lbs)

LIMITED WARRANTY

Pleasure	Three Years
Government	Three Years
Commercial	One Year

FEATURES

POWER/PERFORMANCE

- Command Link® Digital Electronic Controls▲
- High Output Four Stroke V6 Outboard
- Plasma-Fused Sleeveless Cylinders
- Narrow 60° Block Design
- Variable Camshaft Timing
- Long Track Induction System
- Electronic Multi-Point Precision Fuel Injection
- 6 Independent Fuel Injectors
- 4 Large Radius Valves Per Cylinder
- High Intake Valve Lift
- Double Overhead Camshafts
- In-Bank™ Exhaust
- Exhaust Pressure Reduction System
- Compact, Lightweight Design
- California C.A.R.B. Ultra Low Emissions 3 Star Rating
- Meets all current Federal EPA Emission Standards

RELIABILITY/DURABILITY

- TCI Microcomputer
- Electronic Single Throttle Valve (75mm)
- Direct Drive System
- Wet Sump Lubrication
- Engine Warning System
- Sacrificial Anodes
- Water Cooled Rectifier/Regulator
- Water Separator
- Direct Ignition
- YDC 30 Aluminum Alloy
- ACP 221 Paint Process
- Electro-deposited Powerhead Paint Process
- Top Mounted Electrical
- High Output Alternator
- SST Drive, Prop, Shift Shafts
- SST Steering Tube
- Magnetic Drain Plug
- Dual Water Intake Gearcase
- Alumite Exhaust Annodization
- Water Draining Air Intake Duct

CONVENIENCE/CONTROL

- Command Link Plus Display Gauge Compatibility▲
- Power Trim & Tilt
- Freshwater Flush
- Easy Maintenance
- Vibration Reduction Mounting System
- Reversible PTT Switch
- Counter Rotation "LF" Model
- Yamaha Diagnostic System
- Multi-Charge Monitoring System
- Single Cogged Timing Belt System

This document contains many of Yamaha's valuable trademarks. It may also contain trademarks belonging to other companies. Any references to other companies or their products are for identification purposes only, and are not intended to be an endorsement.

Due to Yamaha's ongoing commitment to product improvement, we reserve the right to change without notice, equipment, materials, or specifications.

The information and data contained herein is approximate and subject to many factors and variables, including but not limited to atmospheric, water, and equipment conditions, and operator ability. Therefore, such information and data is provided as a guideline only.

▲ Consult appropriate Yamaha rigging information and Yamaha Rigging Sheet (YMBS) for complete rigging compatibility and requirements information for particular configurations. All rigging items sold separately.

© 2010 Yamaha Motor Corporation, U.S.A. All rights reserved.



YAMAHA MARINE

HOT SHEET

New

EFFECTIVE NOVEMBER 1, 2009

YAMAHA V-6 OFFSHORE OUTBOARDS *four stroke*

Introducing the Next Generation of Yamaha Offshore Outboards

Yamaha proudly announces the next generation of V6 Offshore four stroke outboards, the F300, F250, and F225. Purpose-designed for offshore use, they all feature 4.2 liters of class-leading V6 displacement, yet with significantly less weight than their predecessors, thanks in part to “break-through” engineering never before used in marine engines. In addition, all models can use Yamaha’s new Command Link® Plus rigging system.▲ Complete with Yamaha’s signature four stroke convenience, and reliability – as well as corrosion resistance – they represent the absolute leading edge of high-performance offshore outboard technology.

- **Less: Lightest Weight** – at 562 pounds, the F300 is 242 pounds lighter than the V8 it replaces, while the 250hp and 225hp V6 models weigh up to 47 pounds less than other Yamaha V6 four stroke outboards of comparable horsepower. It is also up to 73 pounds lighter than competitive 300hp four stroke outboards.**
- **More: 4.2 Liters of Big-Bore V6 Displacement** – using the first marine application of plasma-fused sleeveless cylinders, displacement is increased without enlarging the outer diameter of the cylinder, resulting in an outboard with the largest displacement in its class.
- **Less: Time-to-Plane (Fastest Acceleration)** – the naturally aspirated big-bore Yamaha F300 four-stroke outboard has the fastest acceleration of any 300hp V6 four stroke currently on the market.
- **More: Throttle Response** – instantaneous, especially in the mid-range, that has to be felt to be believed.
- **More: Best-in-Class Cruise Speed** – up to 19% faster than competitive 300hp four stroke outboards at 4000 rpm.
- **More: Long-Range Fuel Economy** – up to 17% better fuel economy at mid-range RPM than other four stroke 300hp outboards.
- **More: Best-in-Class Charging Power** – a powerful 70-amp alternator offers charging output over 29% higher than its 300hp V6 four stroke competitor.
- **More: Control** – works with Yamaha’s new Command Link Plus Digital Electronic Controls, rigging system, and hardware for the utmost in control and convenience.
- **More: Convenience** – popular and useful features like Variable Trolling RPM Control are standard. It can even be rigged to external NMEA-2000® compatible displays or analog gauges.▲
- **Less: Noise and Vibration** – cutting-edge Yamaha four stroke design and a new Long Span Mounting System give you increased opportunity to quietly approach your quarry, while a new patented shift dampener propeller hub system (SDS™) reduces the “clunk” that sometimes occurs on larger outboards when shifting into gear.
- **More: Reliability** – designed, built and extensively tested to Yamaha’s stringent standards for durability.



AVAILABLE MODELS: F/LF300XCA • F/LF300UCA • F/LF250XCA • F/LF250UCA • F/LF225XCA

**Published weight

▲ Consult appropriate Yamaha rigging information and Yamaha Rigging Sheet (YMBS) for complete rigging compatibility and requirements information for particular configurations. All rigging items sold separately.



Yamaha V-6 Offshore Four Stroke Outboards

FEATURES

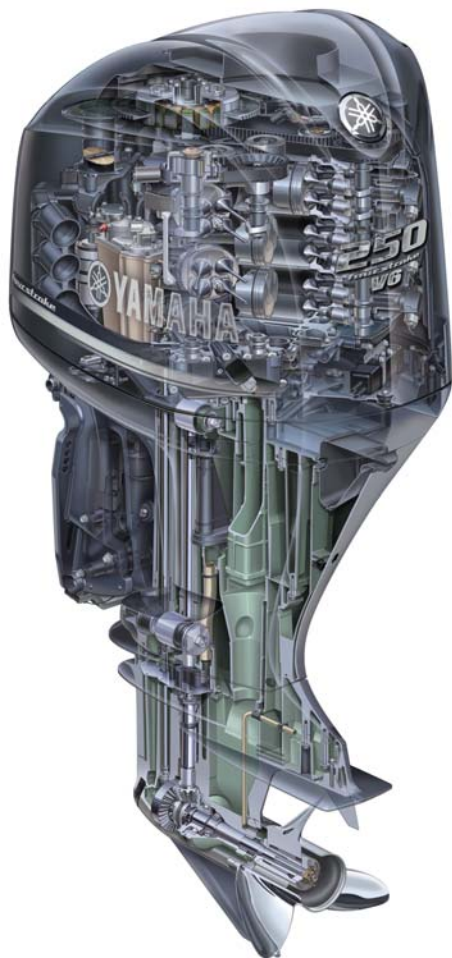

MODEL CODE CHART (EXAMPLE)

LF Rotation and Fuel Induction	250 Horsepower	X Shaft Length	Starting Method PTT	C Control Method	A Generation
L = Left Hand F = Four Stroke		S = 15" L = 20" X = 25" U = 30" J = Jet	Blank = PTT & E start P = PT & E start E = Electric Start M = Manual Start	Blank = Remote Control H = Tiller Handle C = Command Link Control	A = 1st change on motor B = 2nd change on motor C = 3rd change on motor Etc.



RIGGING OPTIONS

GAUGES[▲]

- | | |
|-------------------------------|------------|
| • Command Link® Plus Display | Compatible |
| • Command Link | Compatible |
| • Yamaha Multifunction | Compatible |
| • External NMEA-2000® Display | Compatible |
| • Analog | Compatible |

CONTROLS[▲]

- | | |
|---|----------------|
| • Command Link Plus Digital Electronic Controls | Compatible |
| • Command Link Digital Electronic Controls | Compatible |
| • Mechanical (Cable) | Not Compatible |

KEY SWITCHES AND LANYARDS[▲]

- | | |
|---------------------|------------|
| • Command Link Plus | Compatible |
| • Command Link | Compatible |
| • Conventional | Compatible |

MISCELLANEOUS[▲]

- | | |
|--------------------------|------------|
| • Command Link Gateway | Compatible |
| • Analog Gauge Interface | Compatible |
| • Command Link Triducer® | Compatible |
| • Y-COP™ (Immobilizer) | Compatible |
| • Variable Trolling RPM | Compatible |

[▲] Consult appropriate Yamaha rigging information and Yamaha Rigging Sheet (YMBS) for complete rigging compatibility and requirements information for particular configurations. All rigging items sold separately.

Yamaha V-6 Offshore Four Stroke Outboards

FEATURES



Power/Performance

- ECM Micro-Computer Control
- Closed Fuel Vapor System
- Variable Trolling RPM
- Water Cooled Rectifier Regulator
- Large Water Separator with Water Sensor

- Labyrinth Exhaust
- Water-Sealed Outer Wall

- Vibration Reduction Mounting
- Dual Water Inlet
- Exhaust Pressure Reduction System
- Shift Dampener System (SDS)
- Counter Rotation System
- Propeller: Saltwater Series II™ - SDS™/HS4™



Reliability/Durability

- 70-Amp High Output Alternator



Convenience/Control

- Plasma-Fused Sleeveless Cylinders
- VCT: Variable Camshaft Timing
- Multi-Point Electronic Fuel Injection
- Direct Coil-in-Cap Ignition
- 24-Valve, DOHC, 60-deg V6
- In-Bank™ Exhaust
- Tuned Long Track Intake Manifold
- Blow-By Gas Re-Burning System
- Digital Electronic Throttle & Shift

- Water Draining Air Intake Duct
- Location Exchangeable PTT Switch
- Elegant, Sleek, Light Weight Design
- Lightweight Polymer Bottom Cowling

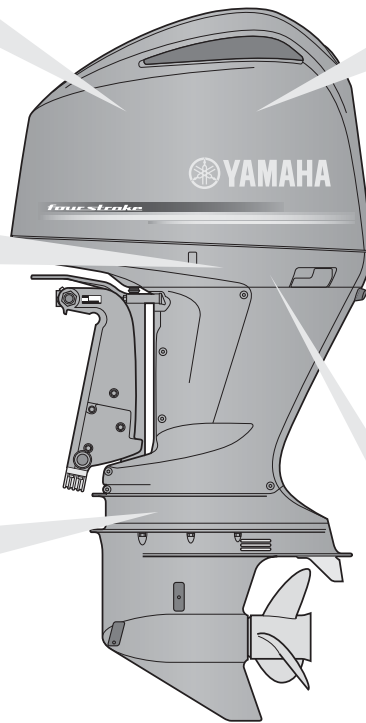

Convenience & Control

- New Command Link Plus Display and Key Panels (optional)
- Command Link Plus or CommandLink Digital Electronic Controls
- Command Link Plus or Command Link Rigging System

Warning & Protection Systems

- Over-Heat Warning
- Over-Rev Limiter
- Low Oil Pressure Warning
- Sensor Compation System
- YDIS: Yamaha Diagnostic System
- Y-COP™ Immobilizer System (optional)

Enhanced Ultimate Corrosion Protection System (UCP-II™)

- Special Aluminum Alloy: YDC30
- Self-Sacrificing Anodes
- Freshwater Flushing Device
- Electro-deposited Inside/Outside Paint Process
- Anodic Exhaust Coating (Alumite)

Yamaha V-6 Offshore Four Stroke Outboards

PERFORMANCE TEST DATA

4.2 LITER BIG BORE DISPLACEMENT

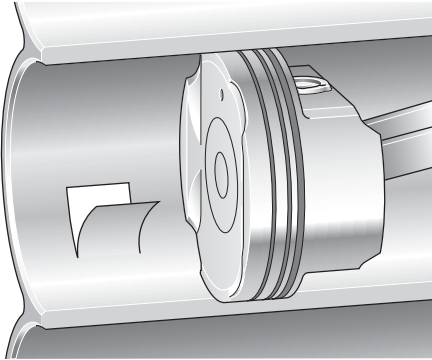

DISPLACEMENT COMPARISON

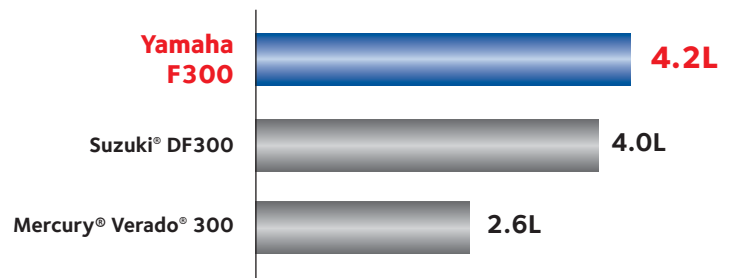

By using a highly-advanced thermally-applied plasma fusion process on the cylinder walls, Yamaha's new line of V6 Offshore outboards have no conventional steel cylinder sleeves, yet the cylinder walls are 60% harder than steel. That means larger cylinder bores for increased displacement, resulting in more power and torque, without increasing outer cylinder dimensions. It also results in dramatically lighter weight, better cooling, and "micro-textured" cylinder walls that help decrease friction loss, and further increase performance and enhance reliability.

LIGHTEST WEIGHT IN CLASS



WEIGHT COMPARISON*

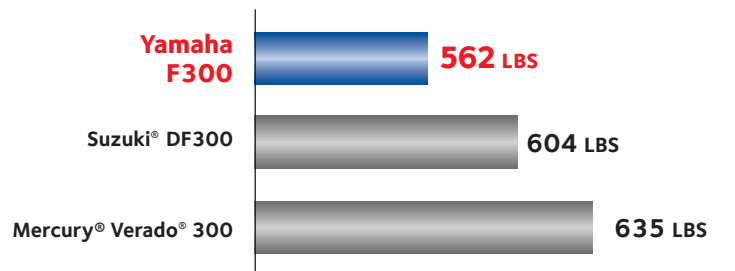

From the top of the cowling to the tip of the prop shaft, every ounce of weight-savings has been realized for maximum performance without sacrificing durability. There's even a new advanced polymer composite lower engine pan that lowers weight and increases corrosion resistance.

*Published weight

Yamaha V-6 Offshore Four Stroke Outboards

PERFORMANCE TEST DATA

THROTTLE RESPONSE AND ACCELERATION

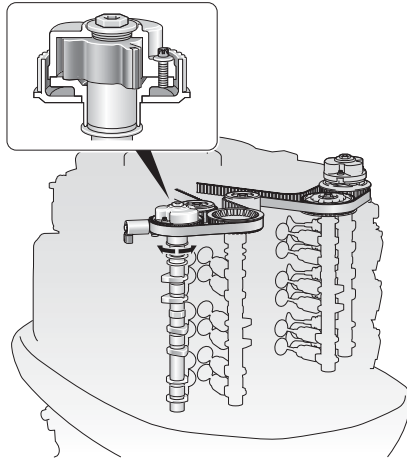

TIME-TO-PLANE COMPARISON

(Grady White® 257 Advance)

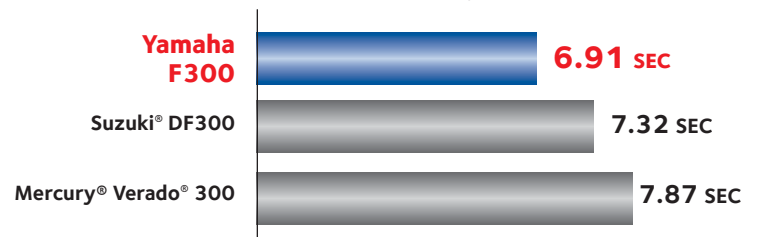

Yamaha's Variable Camshaft Timing system advances and retards the angle of the intake camshaft to dramatically increase power and throttle response in the low- and mid-rpm ranges. This feature helps Yamaha's new 4.2 liter big-bore V-6 Offshore Outboard to deliver awesome hole shot and mid-range acceleration you have to feel to believe.

BEST-IN-CLASS FUEL EFFICIENCY

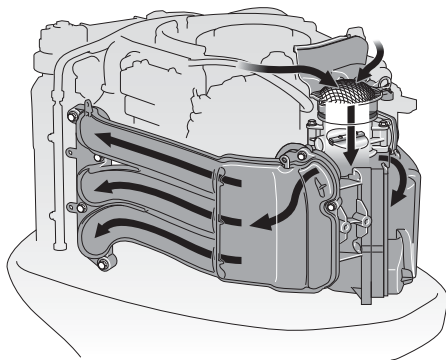

FUEL EFFICIENCY* COMPARISON (3500 RPM)

(Grady White® 257 Advance)

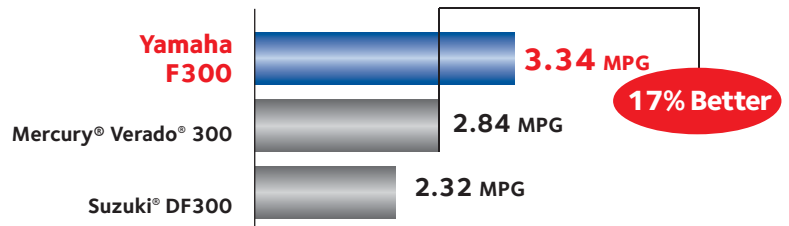

Yamaha's 300hp V6 Offshore outboard has up to 17% better long-range fuel economy at 3500 rpm than other 300hp 4 stroke outboards. All air entering the engine block of each Yamaha V6 Offshore outboard is routed through a single 75mm electronically-controlled throttle valve. Working in concert with the Precision Multi-Point Fuel Injection System, together they help ensure the precise amount of air and fuel necessary for optimum power and fuel efficiency. The reduction in friction from the Micro-Textured Cylinder Walls further adds to this outboard's amazing fuel economy.

*Per Yamaha On-Water Testing

Yamaha V-6 Offshore Four Stroke Outboards

PERFORMANCE TEST DATA

CRUISING SPEED



SPEED AT CRUISE (4000 RPM)

(Grady White® 257 Advance)

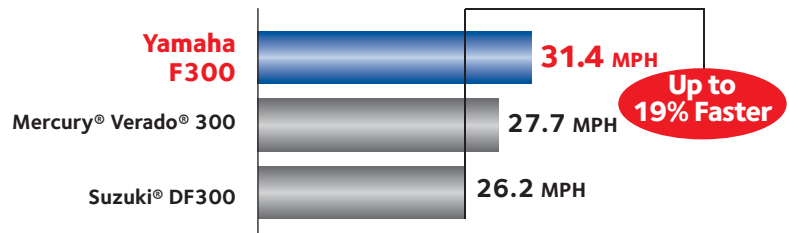

The Yamaha F300 is up to 19% faster at cruise rpm than other 300hp four stroke outboards. Cruise rpm is where most offshore outboards are typically operated, meaning you get there faster, using less fuel, than competitive models.

BEST-IN-CLASS CHARGING POWER

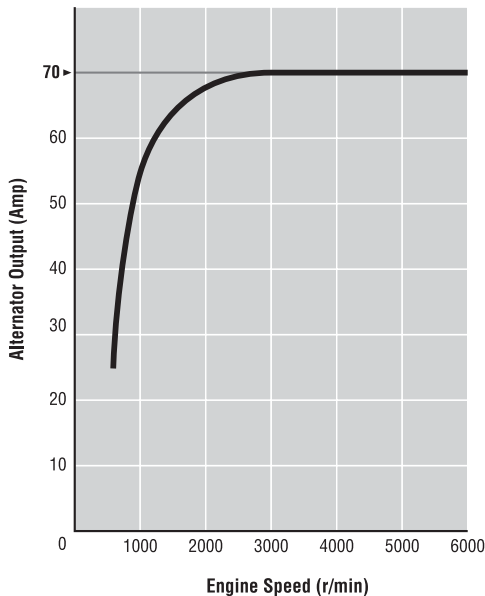

ALTERNATOR OUTPUT*

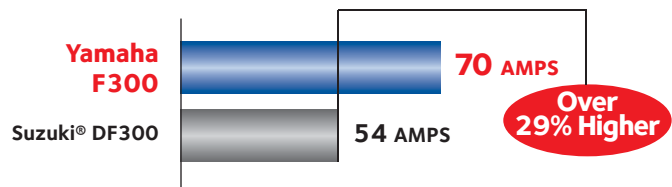

With 70 amps of total alternator output, Yamaha's new V6 Offshore outboards have over 29% higher total alternator power than other V6 four stroke outboards. That kind of charging power is vital to help operate today's wide array of on-board electronic devices.

*Published alternator output

Yamaha V-6 Offshore Four Stroke Outboards

OPTIONS AND UPGRADES

COMMAND LINK PLUS RIGGING COMPATIBILITY

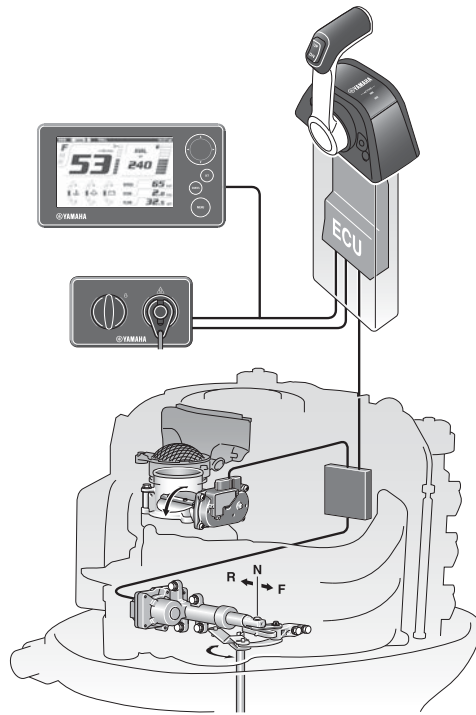

Yamaha V6 Offshore outboards are compatible with Yamaha's new Command Link Plus rigging system. Featuring a new 5" high-contrast, multi-engine, LCD display; new Command Link Plus Digital Electronic Controls; new key switches and start/stop panels; and new Command Link Plus accessories, this system offers more convenience, flexibility, and information than ever before. There's even the optional new Y-COP™ Immobilizer system, which allows the operator to disable the outboard's ignition system using a battery-operated key fob during periods of non-use.



(Optional)

PATENTED SHIFT DAMPER SYSTEM (SDS™)

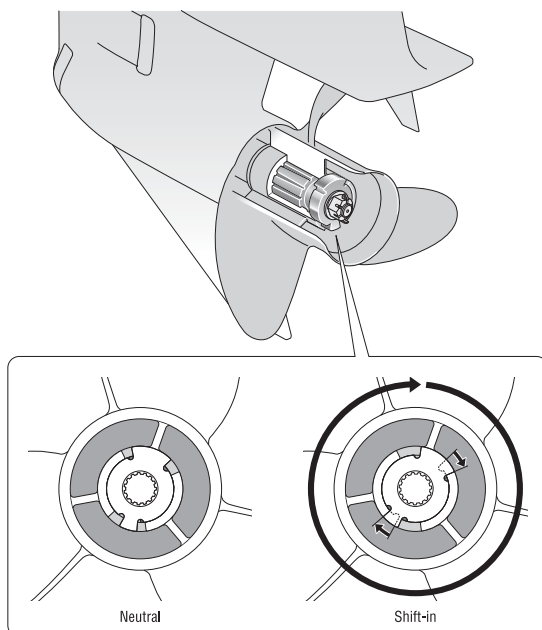

Yamaha's patented new Shift Dampener System (SDS) greatly reduces noise commonly associated with shifting gears. Using a special new design and components, much of the resulting force is absorbed, resulting in far quieter and smooth operation. Initially available on Saltwater Series II™ – SDS propellers, which are ideal for these outboards and their typical applications. They are available in 13", 15", 17", 19", 21", and 23" pitches. The 13" and the 23" pitches are new to the Saltwater Series II line up.

Yamaha V-6 Offshore Four Stroke Outboards

RELIABILITY AND DURABILITY

PROTECTION FROM THE ELEMENTS

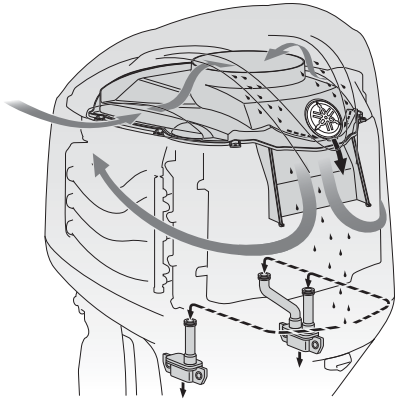

All Yamaha V-6 Offshore outboards feature a proven cowling drain system, to easily and efficiently drain away any water that enters the cowling during normal engine operation. Incoming air is routed through a labyrinth of passages that trap and drain water before it enters the engine's intake, for maximum reliability.

PROTECTION AND POWER

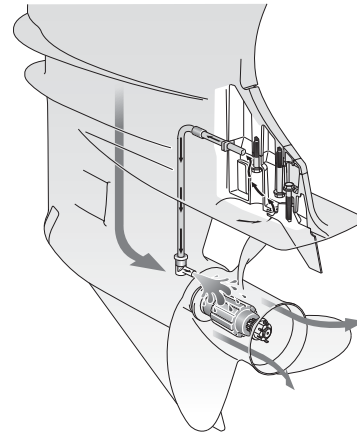

Yamaha V-6 Offshore outboards feature an exhaust pressure reduction system, which not only helps keep the propeller hub cooled from hot exhaust gases, it also helps provide more power by helping to force those gases out of the engine.

INCREASED COOLING CAPACITY

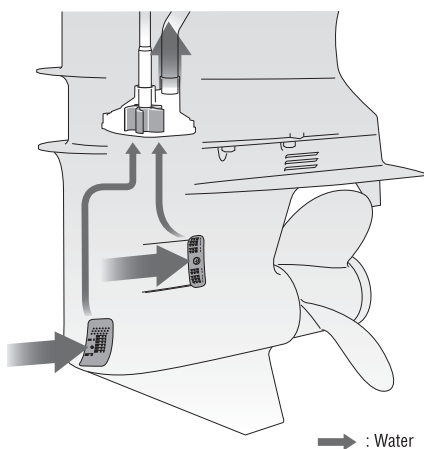

Yamaha V6 Offshore models come standard with dual pairs of water inlets, for increased cooling efficiency. Located on the front and both sides of the lower unit, each pair of pick-ups operate independently of each other to provide proper water flow in a wide variety of applications and conditions.

RELIABILITY AND EFFICIENCY

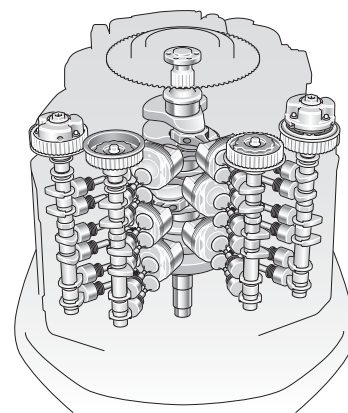

4.2 liters of class-leading displacement teams with individual intake and exhaust camshafts to provide more precise valve timing control with fewer moving parts than conventional rocker arm systems for increased reliability. This superior design also allows for use of 4 valves per cylinder which exchange intake and exhaust gases more efficiently for responsive power and increased fuel economy.

Yamaha V-6 Offshore Four Stroke Outboards

CONVENIENCE AND CONTROL

PRECISE AND CONVENIENT TROLLING

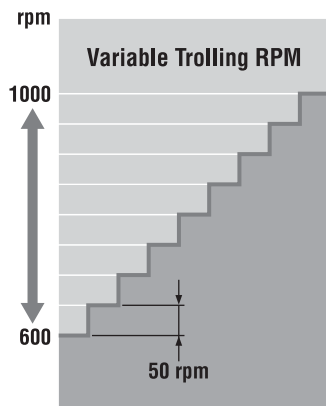

Controlled by a Command Link Plus digital display or a Command Link tachometer, the operator can adjust the engine's trolling speed from 600 ~ 1000 rpm, in 50-rpm increments. This helps provide precise and consistent trolling speeds in a wide array of conditions.

VIBRATION REDUCTION

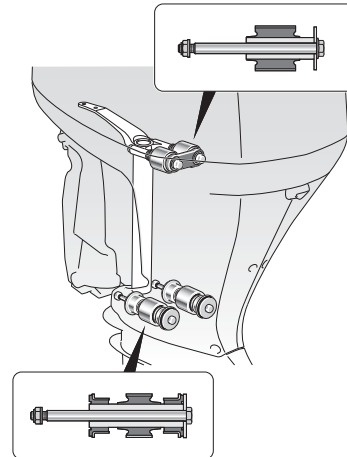

Yamaha V-6 Offshore outboards utilize a new version of our Long Span Mounting System, which employs a specially-formulated rubber compound attached to newly-designed engine mounts. Placed as far apart vertically and horizontally as practically possible, they provide necessary strength while minimizing vibration.

SMOOTH AND QUIET

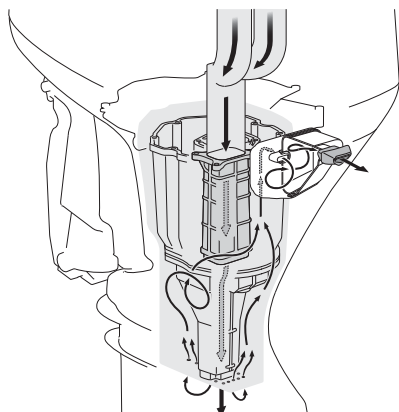

Engine exhaust is routed through a maze before exiting above the waterline through the idle exhaust relief outlet, for unbelievably smooth and quiet operation.

ADVANCED TECHNOLOGY

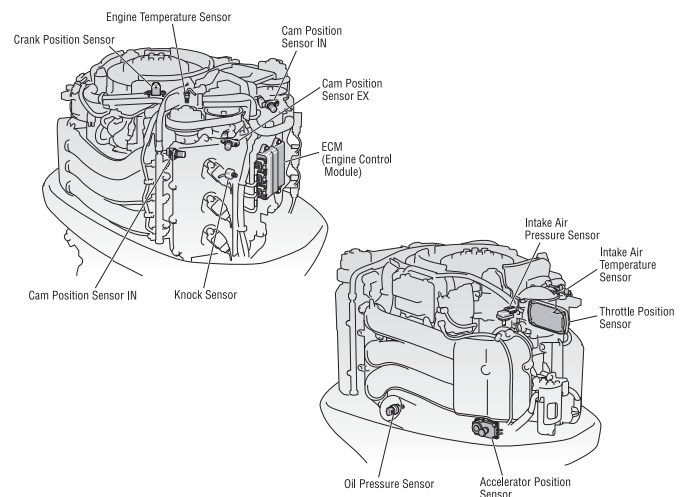

Six individual sensors constantly provide vital atmospheric and engine conditions to the Engine Control Module (ECM), which instantly makes the precise adjustments for optimum performance and efficiency.

Yamaha V-6 Offshore Four Stroke Outboards

DIMENSION SPECIFICATIONS

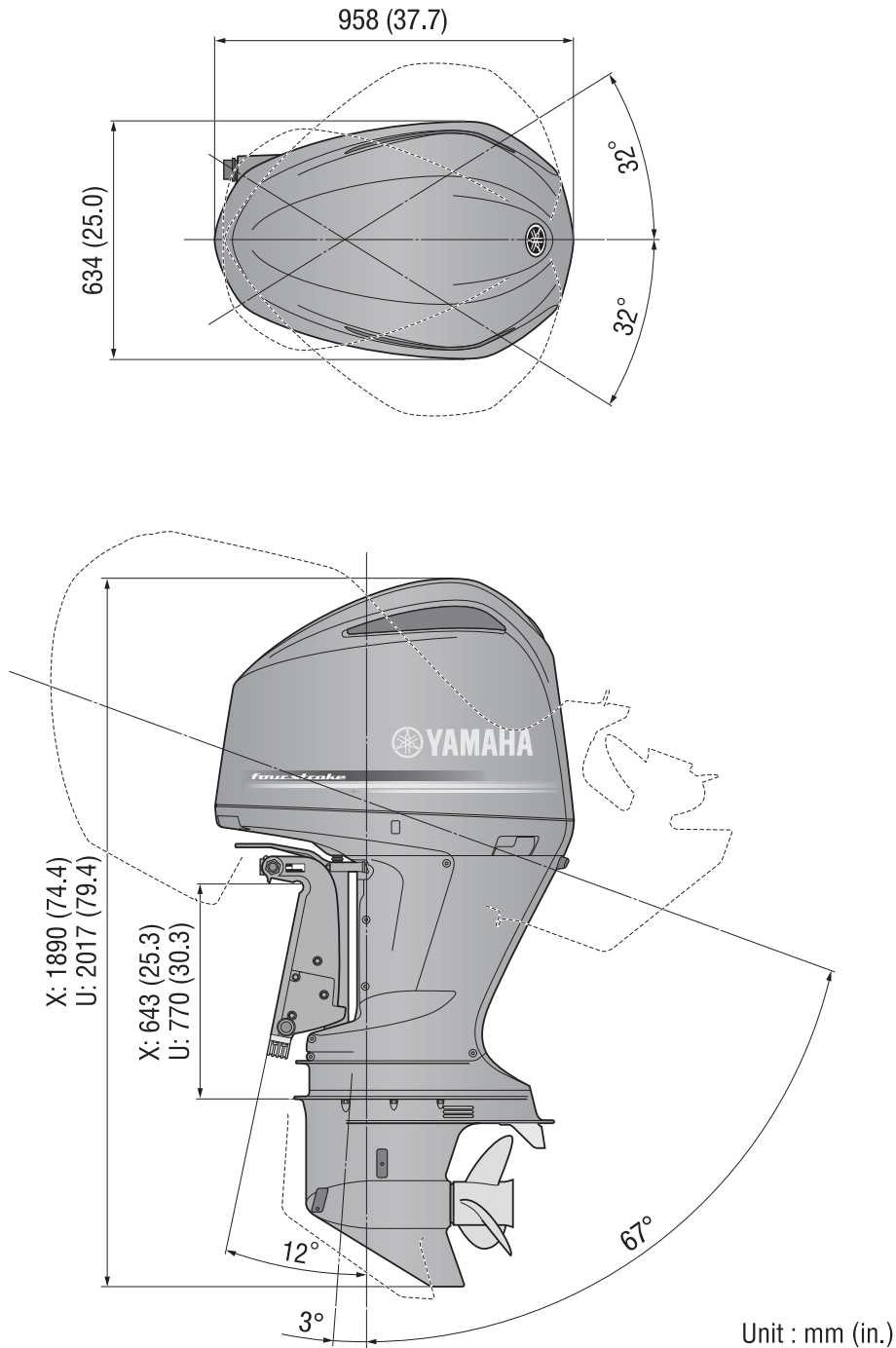

The break-through four stroke technology used in Yamaha's V-6 Offshore outboards help keep exterior dimensions surprisingly compact, and the 32° maximum steering angle to the left or right helps give you excellent control.

Yamaha V-6 Offshore Four Stroke Outboards

V-6 OFFSHORE SYSTEM

